

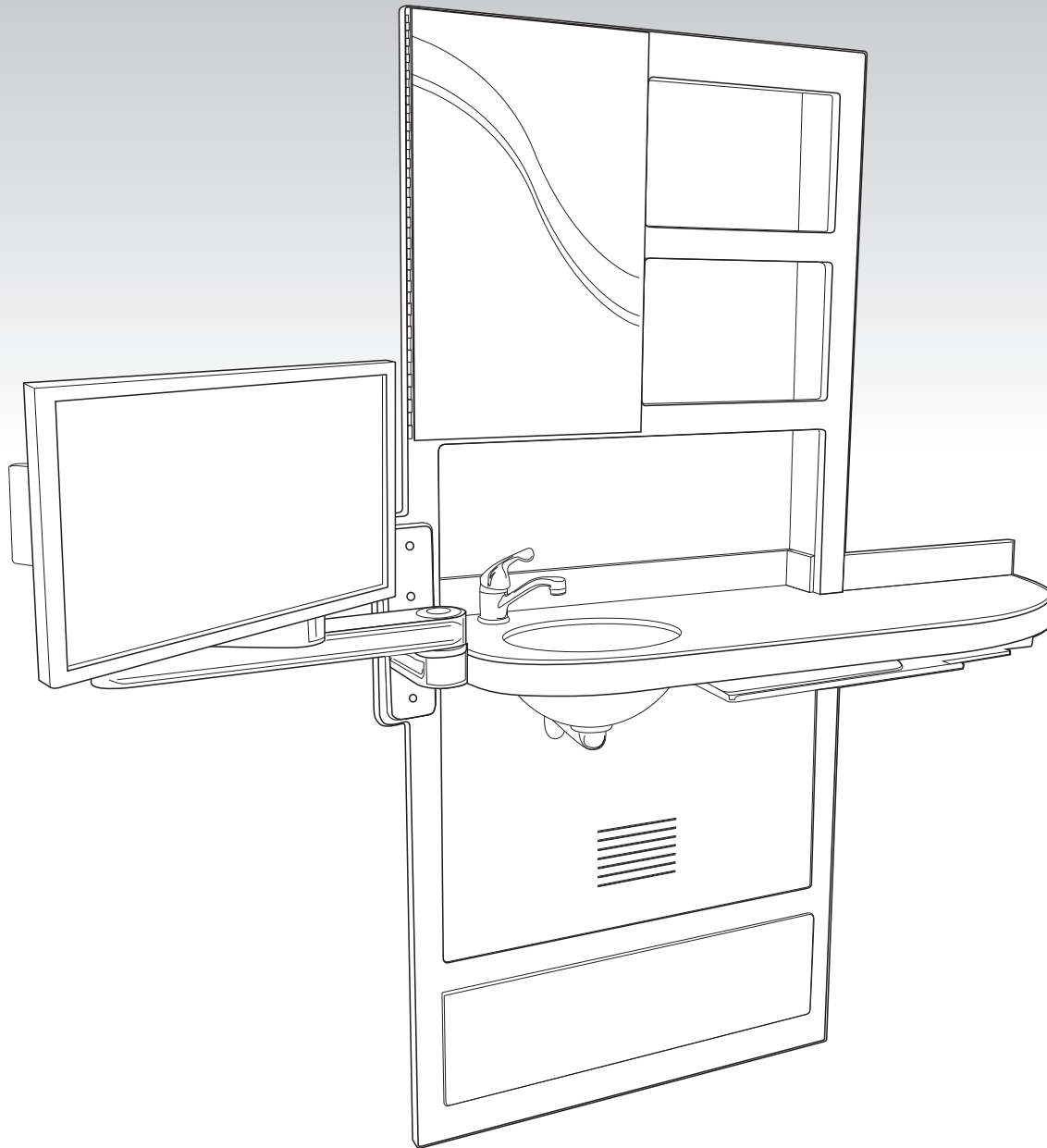

ergonomic products  
Performance Without Compromise™

## Specification and Installation Guide

# 32" INWALL™ COMFORT MEDIA



Monitor not included

Left mounted sink shown.  
CORIAN® counter extension to right.

Product ID: **N3C**  
950-094 Manual version: **E**



**Thank you** for purchasing the Ergonomic Products 32" Inwall™ Comfort Media.

Years of research by dentists, engineers and designers have made this a uniquely effective product in the industry. We stand behind our equipment, and genuinely believe it to be the best available on the market.

Should you have any questions regarding the product's installation or use, please don't hesitate to call our customer service specialists at **1-866-ERGO-4-US**. We may also be reached via email at **equip@ergonomic-products.com**.

We hope you enjoy the benefits and quality of your new equipment and look forward to handling your future needs as you and your practice continue to grow!

*- The Ergonomic Products Team*

**CONTENTS:**

1. Specifications and Site Planning .....	3
2. Required Tools / Unpacking and Inspecting .....	5
3. Installation .....	6
4. Maintenance .....	10

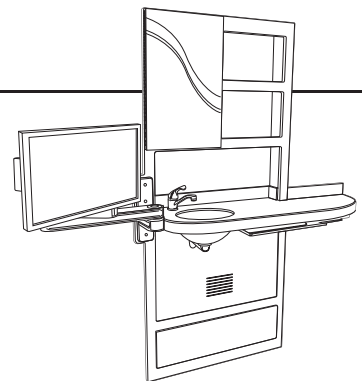

## QUESTIONS?

**Call our Customer Service Specialists at:  
1-866-ERGO-4-US.**



# 1 - SPECIFICATIONS and SITE PLANNING

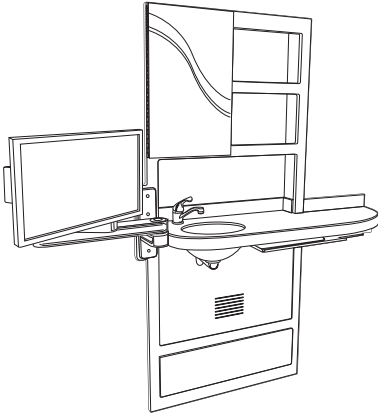

### USE & FEATURES

- Inwall storage cabinet
- Counter space
- Digital Media Presentation
- Sink

### VARIANT/OPTION NOTATIONS

Sink mounted LEFT  
Counter extension RIGHT

*Note: Product also available with RIGHT mounted sink, or without sink. Confirm accuracy of product prior to installation.*

### BASIC UTILITY REQUIREMENTS

#### \*Plumbing

- Hot & Cold feed lines
- Drainage & venting

#### Electrical

- 120v feed (outlet)
- Intra/Inter-net feed (data-port)

\*If unit is purchased without sink, disregard plumbing requirements.

### IDEAL LOCATION CONFIGURATION

*Left Sink with Right Counter Extension, ideally for Right Handed Doctor rooms.*

*To maximize monitor arm geometry, the 32" Comfort Media should be placed roughly 5' 6" from the headwall (as shown). Dimensional tolerance of 6" will allow maximum effect for patient presentation and treatment planning.*

*For alternate room layouts or equipment configurations, position unit so that right side of cabinet lines up with head of chair when reclined.*

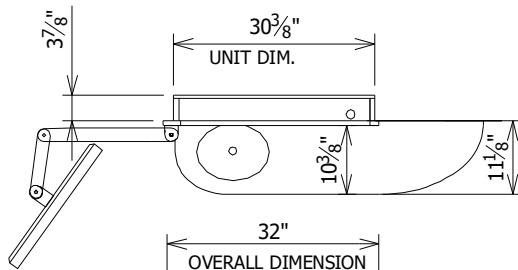
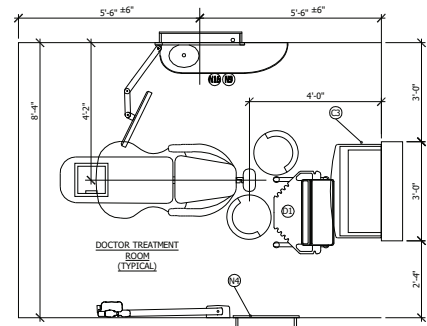

### DIMENSIONS

**NOTE: All Height Dimensions are referenced away from the FINISHED FLOOR ("AFF").**

**When planning the Rough Opening, it is critical to measure from the installed Finish Floor, or account for its eventual depth if it is not yet installed.**

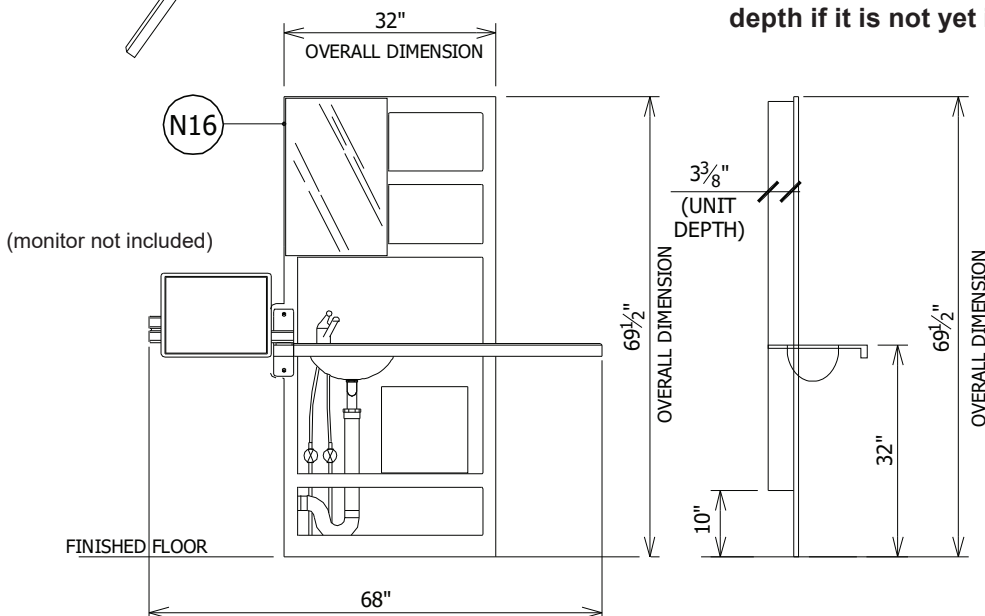



# 1 - SPECIFICATIONS and SITE PLANNING CONT'D

## ROUGH OPENING

**NOTE: All Height Dimensions are referenced away from the FINISHED FLOOR ("AFF").**  
When planning the Rough Opening, it is critical to measure from the installed Finish Floor, or account for its eventual depth if it is not yet installed.

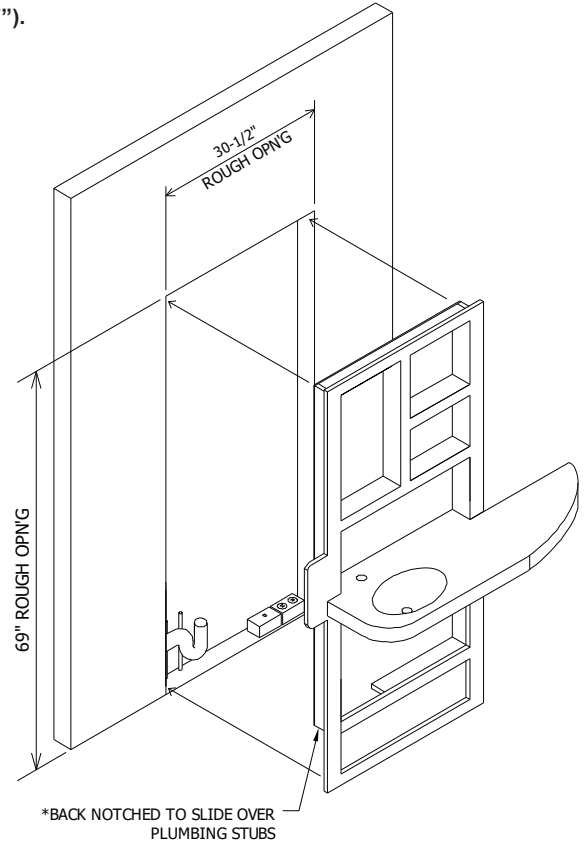
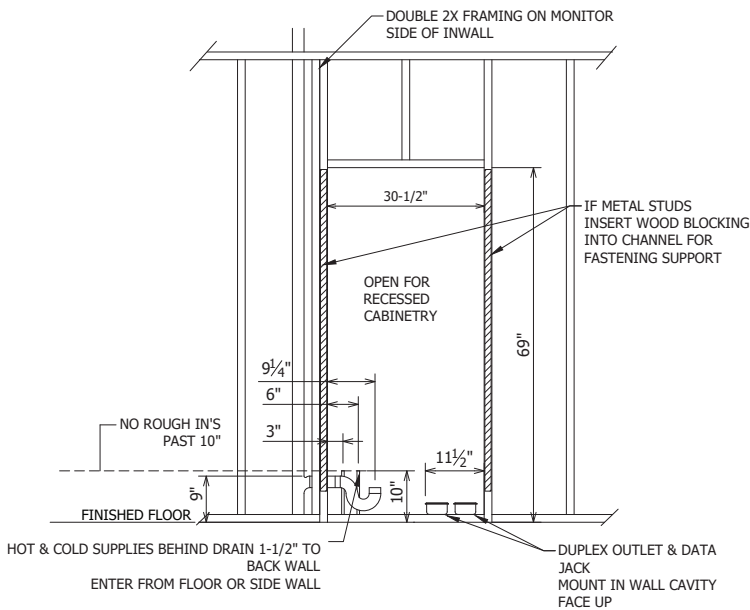

## UTILITY SPECIFICATIONS AND DETAIL

**NOTE: All Height Dimensions are referenced away from the FINISHED FLOOR ("AFF")**

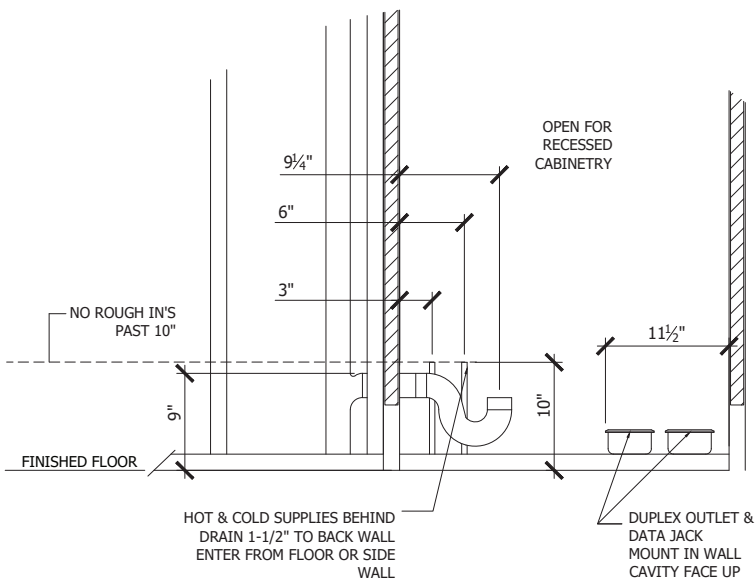

### ⚡ Electrical Specifications

120v Duplex Outlet  
(computer and monitor)  
Cat 5 (or better) Data Jack

### 💧 Plumbing Specifications

Unit is supplied with Delta 570 Single Lever Faucet and 1-1/4" 90° Tail-pipe.

Plumber to provide:

- 1/2" Hot & Cold domestic supply lines with straight 1/4 turn-stop and 3/8" compression
- 1-1/2" DWV with P-Trap as shown



## 2 - REQUIRED TOOLS / UNPACKING and INSPECTING

### REQUIRED TOOLS

Phillips Head Screw Driver  
Power Drill  
Impact Drill  
Level

**Two 32" Inwall Comfort Media units and accessories may be packaged in a single crate.**

1. Remove all packing material and accessory boxes from shipping crate.
2. Use safe lifting procedures to free the 32" Inwall™ Comfort Media from the crate and position it near the installation site.
3. Laying individual components on clean surface to avoid scratching, and inspect contents. If damage is found, contact Ergonomic Products immediately.
4. Do not discard accessory boxes without thoroughly confirming they are empty first.

*All claims against the freight carrier must be initiated at the time the damaged items are received. The claim is the responsibility of the customer.*

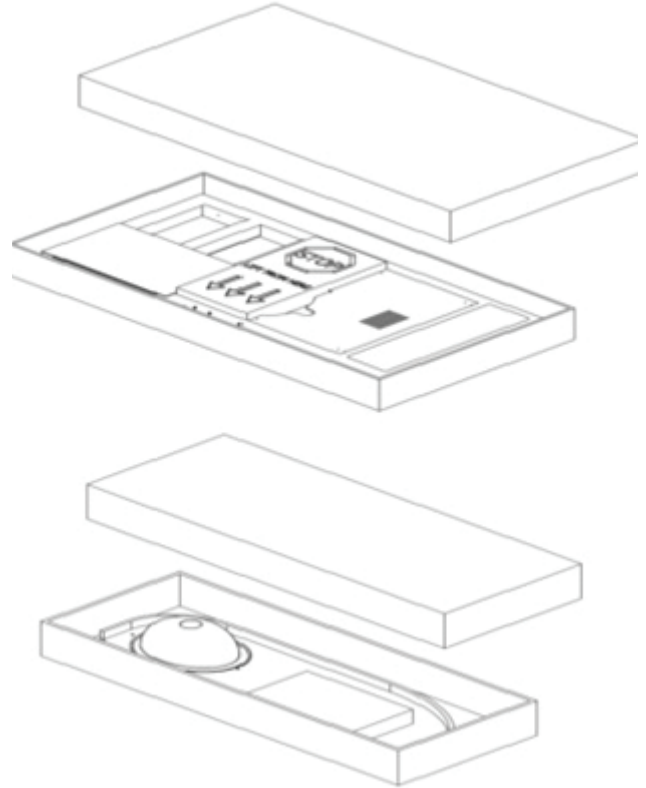

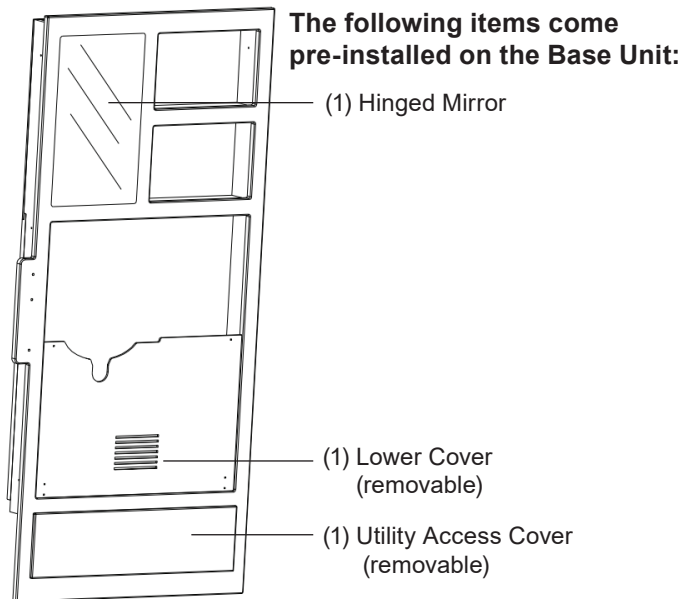

### PARTS LIST

Check that the configuration/options for your product(s) are correct. If anything is damaged or missing, please contact Ergonomic Products customer service at 1-866-ERGO-4-US.



**BASE UNIT**

#### Additional items:

- (1) 1-1/4" 90° Sink Tail-pipe (not included if unit is purchased without sink) 
- (1) Faucet & Strainer
- (1) Self-adhesive Pull Handle (Mount to bottom right corner of mirror)
- (4) #10-32 x 3/4" screws
- (4) #10-32 x 1" screws
- (1) Extended Counter Backsplash
- (2) Side Backsplash
- (1) Rear Backsplash
- (1) 12" x 1" wooden Counter Support Cleat
- (1) 2.8 oz tube of Silicone Adhesive
- (2) Support "L" Brackets 
- (1) Boxed ICW T2 Monitor Mount includes:
  - Mounting Bracket & Screws
  - Media Arm
  - Installation Sheet



## 3 - INSTALLATION



**IMPORTANT!** Consult the specifications on page 4 to confirm the on-site accuracy and conformance of Rough Opening and Plumbing / Electrical Stubbing. Be aware that this product is available in a variety of configurations that will affect site preparation.

The face frame of the 32" Inwall™ Comfort Media is installed at finished floor level and overlaps the rough opening, eliminating the need for finish-work after the unit is installed. However, **any existing baseboard molding will need to be trimmed back approximately 1" from the rough opening** to allow the unit to mount flush against the wall. For cleanest installation, dry-fit the unit and mark scribe lines on the baseboard for trimming (see fig. 3.1).

### STEP 1 - INSERT AND SECURE CABINET

1. Insert unit into rough opening, and confirm clearance on trimmed baseboard (see warning above).
2. Confirm face is evenly flush against wall. If large gaps are present, mark area and cut down wall surface to remove high spots on wall board.  
  
Small gaps can be filled with any paintable grade caulking after installation of the product.
3. While keeping unit flush against the wall, confirm that it is level. If it is not, slightly raise one side until plumb.
4. While keeping unit flush against the wall, secure raised side to studs through pre-drilled mounting holes using three flat head screws\*.
5. Secure other side with remaining three screws\*.

**\*Suggested screw size #8 2-1/2" flat head screw**

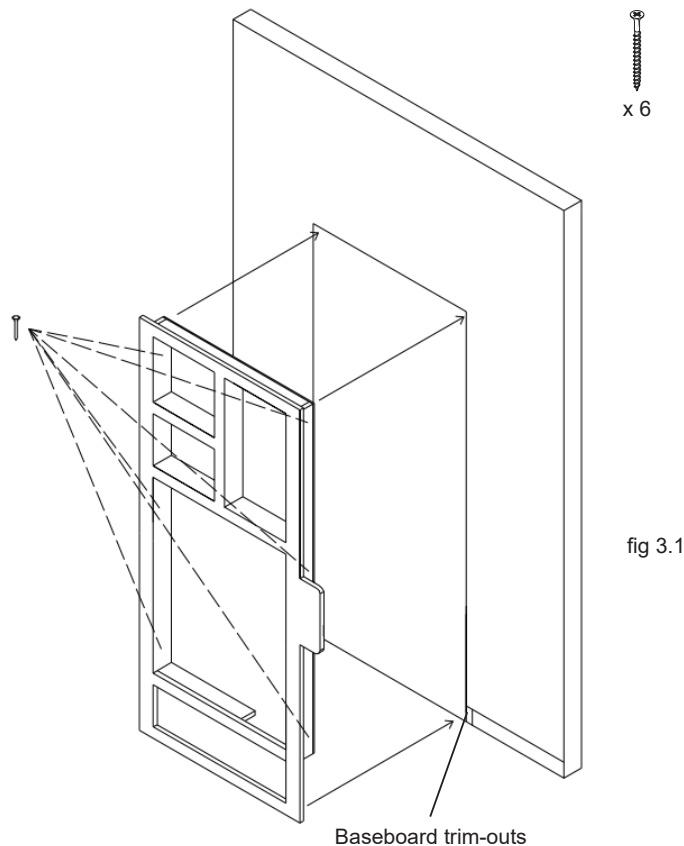



### 3 - INSTALLATION cont'd

#### STEP 2 - INSTALL "L" BRACKETS AND SECURE CORIAN

1. Remove the middle access panel to reveal the mounting holes for the "L" brackets (Fig 3.2).
2. Secure the brackets using four #10-32 x 1" screws (Fig 3.3).

Caution: Do not use power tools when securing screws, hand tighten only!

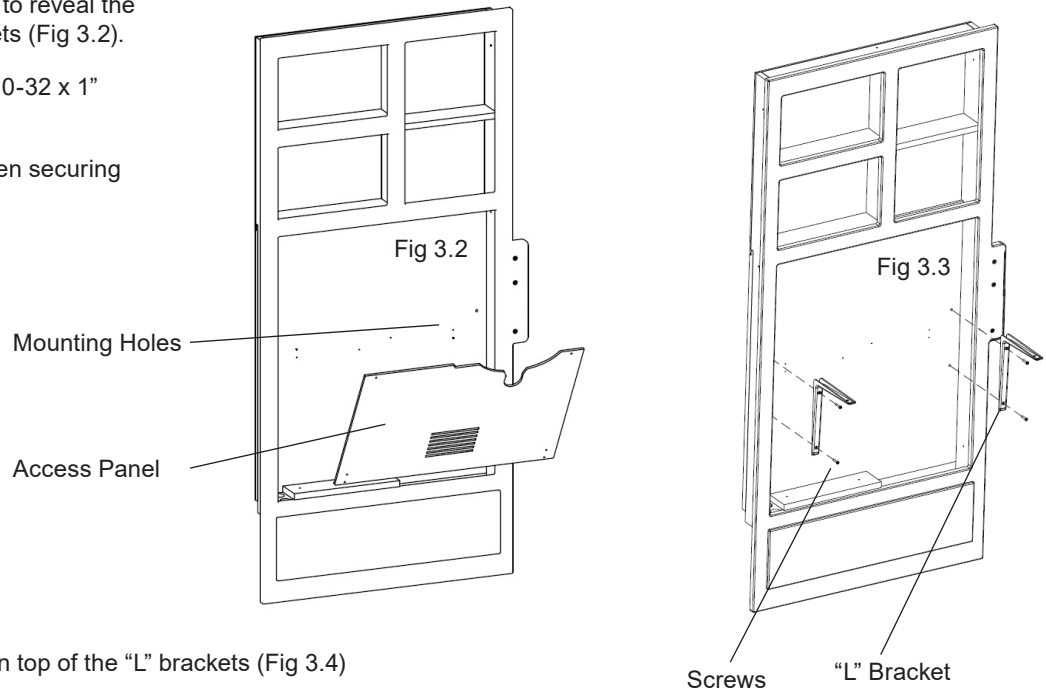

3. Place the Corian Work surface on top of the "L" brackets (Fig 3.4)
4. Secure the Corian using four #10-32 x 3/4" (Fig 3.5)
5. Secure the final four screws from Fig 3.1

Caution: Do not use power tools when securing screws, hand tighten only! Over tightening screws will damage Corian Work surface.

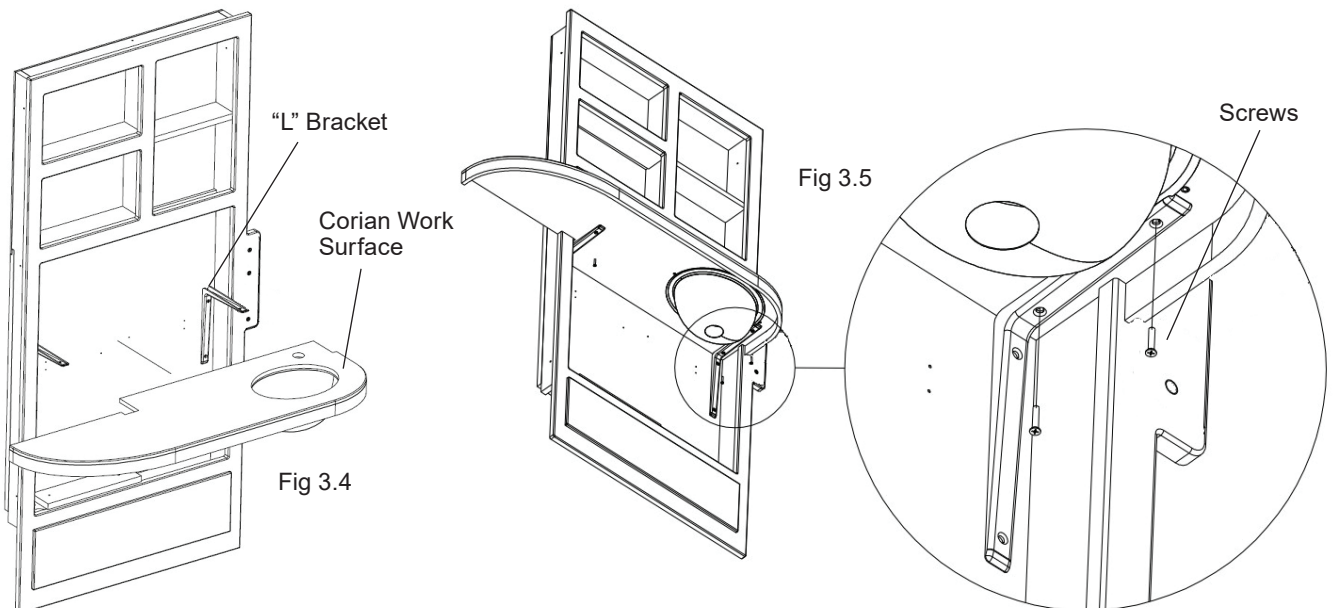



### 3 - INSTALLATION cont'd

#### STEP 3 - INSTALL SUPPORT CLEAT AND BACKSPLASH

The extended counter is supported by a 12" x 1" wooden cleat secured directly to the wall beneath the counter after the main cabinet is secured. The backsplash on this part of the counter is also secured directly to the wall.

1. Apply silicone to the back of the wooden support cleat.
2. Press cleat against wall, keeping firm contact with underside of extended counter (fig 3.6).
3. Secure cleat with three #8 x 2-1/2" flat head screws. Do not overtighten screws; they are simply used to hold the cleat while the silicone sets.

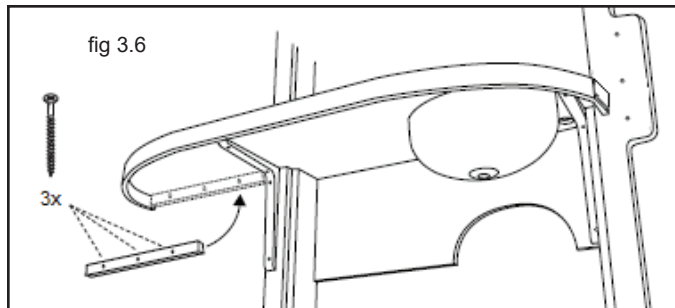

4. Apply silicone adhesive to the back of the backsplash.
5. Press firmly to wall, butting against faceframe (fig 3.7). Be sure to position backsplash with indicator arrow UP.

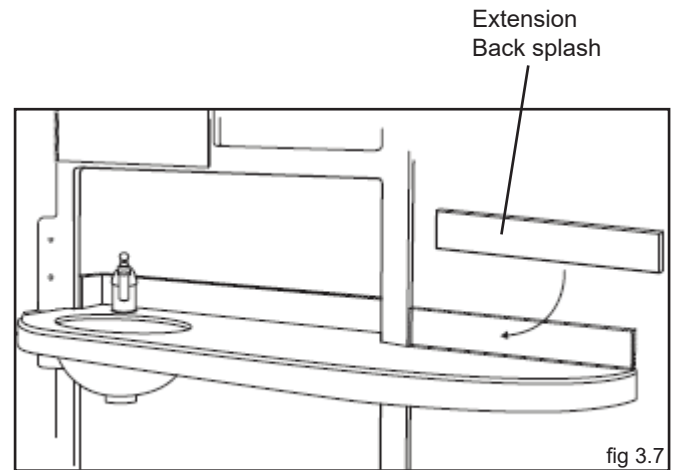

#### STEP 4 - COMPLETE PLUMBING AND COMPUTER INSTALLATION

1. To access plumbing stubbing, remove Utility Access Cover.

Slide cover up to clear lower bracket, tilt bottom towards you and lower cover away from face frame (fig 3.8).

(Reverse this process to replace the cover.)

2. Have a licensed tradesman make final plumbing connections.
3. Position CPU on shelf and run computer and communications cable as desired (fig. 3.9).
4. Replace lower access panel (fig 3.10).

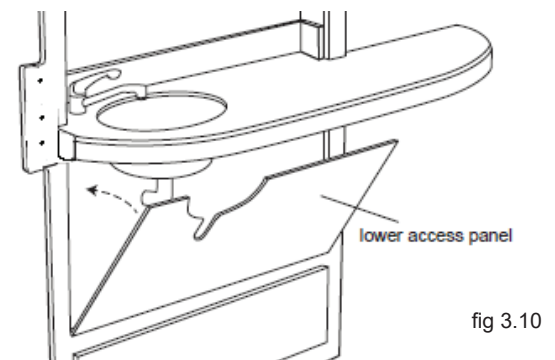
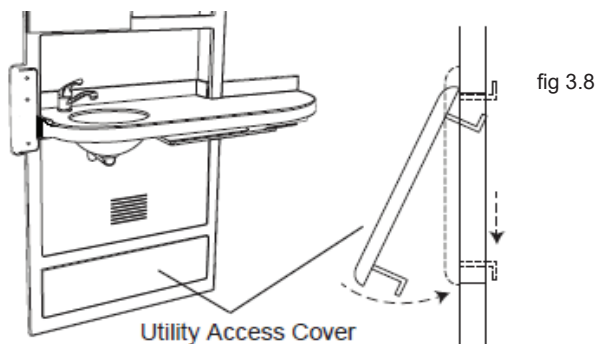
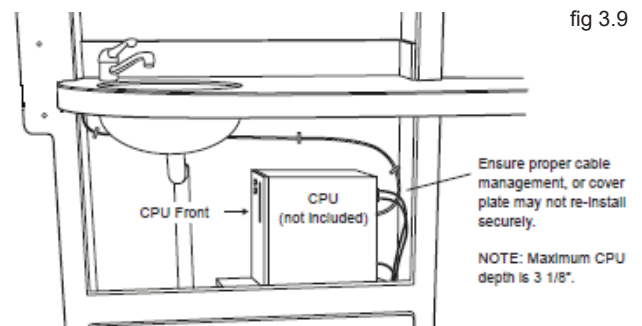





## 3 - INSTALLATION cont'd

### STEP 5 - INSTALL MONITOR ARM

1. Attach ICW Monitor Mount to face frame using 3 #14 Phillips head screws, provided in T2 package (fig 3.11).
2. Complete the Monitor Mount assembly by following the installation instructions provided with the ICW Wall Mount.
3. If you have an optional Handle Bracket for the "Titan Arm" installation is on page 9. If you have the "Elite Arm" option please see page 11

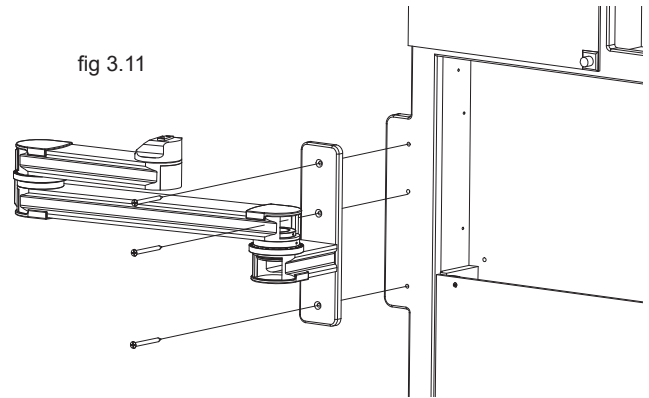

### STEP 6 - INSTALL HANDLE BRACKET (TITAN ARM)

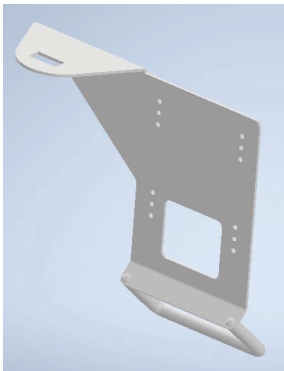

Handle Bracket  
Titan Arm



1. The Monitor Handle Bracket kit will come with all hardware required to mount on your PC monitor. Fig 3.12.

**Hardware - 4 Screws, 4 short spacers, 4 long spacers, 1 Cap, 1 Threaded spacer, 2 shoulder set screws**

2. Place monitor face down on a protected surface. Line up the spacers over the mounting holes as shown in Fig 3.13. Use a small amount silicone to help keep the spacers in place if needed.

*Note - If the back of your PC monitor is flat, use the shorter spacers. If the back of your monitor is curved use the longer spacers.*

3. Place the Monitor Bracket by lining up the holes from the Bracket to the spacers on the monitor and secure with the screws provided. Fig 3.14

*Note - The monitor bracket has a series of holes to position where the handle will be under the monitor. The top set holes will have the handle at its lowest position (away from bottom of monitor). The bottom set holes will have the handle at its highest position (close to the bottom of monitor).*

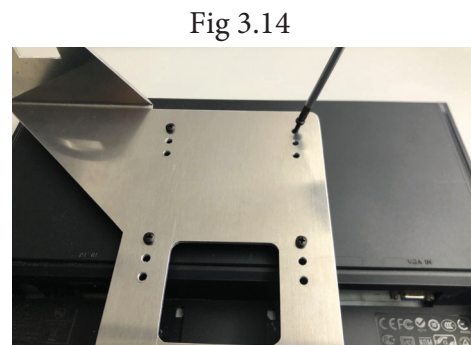



### 3 - INSTALLATION cont'd

#### STEP 6 - INSTALL HANDLE BRACKET (TITAN ARM) - CONT'D

4. Position the wire way opening of the Elite Arm as shown in Fig 3.15. Remove the bottom cap as shown in Fig 3.16. Remove the metal front cover as shown in Fig 3.17.

*Note: if there is any wiring present it should be fed through the arm and out of the wire way hole in preparation for connecting anything to the monitor.*

5. Place the rectangular opening from the Monitor Bracket on to the rectangular standoff from the Titan Arm as shown in Fig 3.18 & Fig 3.19.
6. Line up the Threaded Spacer with the holes from the Elite Arm Fig 3.20.

*You can place a small amount of silicone to help keep the Spacer in place.*

*Note: you will need a helper to hold the monitor in place while securing the Spacer with the screws provided.*





### 3 - INSTALLATION cont'd

#### STEP 6 - INSTALL HANDLE BRACKET (TITAN ARM) - CONT'D

7. Take the 2 Shoulder Set Screws and fasten them from underneath the Titan Arm as shown in Fig 3.21 & 3.22.
8. Return the Metal Front Cover and Bottom Cap back in place. You can refer to Fig 3.16 & 3.17.
9. Take the Cap and place it over the Threaded Spacer as shown in Fig 3.23 & 3.24.
10. Monitor Handle assembly is complete Fig 3.25.

Fig 3.21



Fig 3.22



Fig 3.23



Fig 3.24

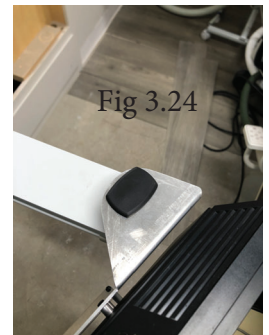
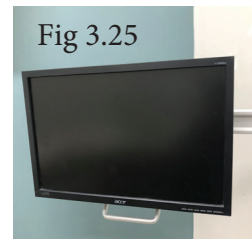

Fig 3.25



#### STEP 7 - INSTALL PULL HANDLE (ELITE ARM)

1. The Monitor Handle Bracket kit will come with all hardware required to mount on your PC monitor. Fig 3.26.  
**Hardware - Preassembled Bracket, and 4 Screws.**
2. Remove the VESA bracket from the Titan Arm by unscrewing the white knob Fig 3.27.

Fig 3.26



Fig 3.27





### 3 - INSTALLATION cont'd

#### STEP 7 - INSTALL PULL HANDLE (ELITE ARM) cont'd

3. Spacers come pre-attached to the bracket, see Fig 3.28. Flip the bracket over, locate the VESA mount over the spacers, line up the holes, and Insert the 4 screws supplied, Fig 3.29.
4. Place monitor face down on a protected surface. Line up the spacers on the bracket assembly, over the mounting holes, and on the back of the monitor as shown in Fig 3.30. Screw down the bracket assembly to the back of the monitor as shown in Fig 3.31.
5. Remount the monitor assembly to the Elite Arm Fig 3.32, and reassemble the white knob in Fig 3.33.
6. Monitor assembly is complete Fig 3.34.

Fig 3.28



Fig 3.29



Fig 3.30



Fig 3.31



Fig 3.32



Fig 3.33

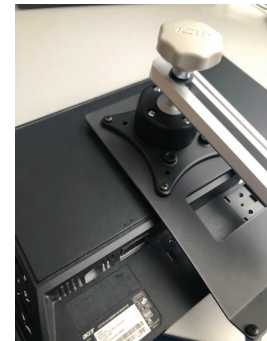
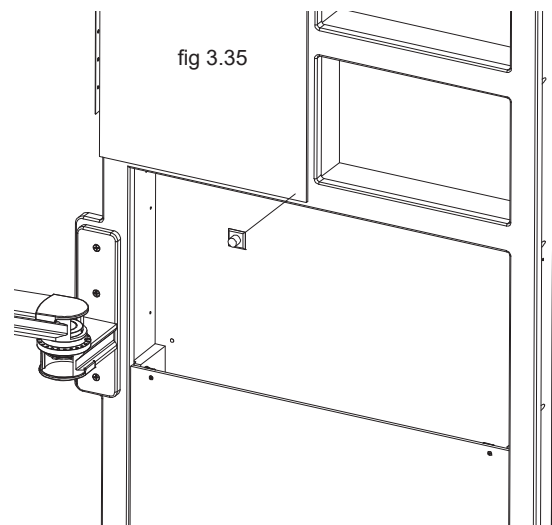

Fig 3.34



#### STEP 8 - INSTALL PULL HANDLE

1. Remove the peel back paper from the pull handle.
2. Stick the self adhesive back of the pull handle to the bottom right corner of the pull mirror (Fig 3.35)





## 4 - MAINTENANCE

### Cleaning instructions

---

#### Painted Surfaces

Clean with mild detergent, damp cloth and dry thoroughly after cleaning.  
Do NOT use alcohol or solvent based cleaners, ScotchBrite or other abrasive pads.

#### CORIAN® Surfaces

Clean with warm, soapy water or any non-abrasive ammonia based cleaner or disinfectant. Dry thoroughly after cleaning. For tougher stains, use Clean EnCounters® from DuPont.

Do NOT use window-cleaning solutions (they will leave a waxy build-up), ScotchBrite or other abrasive pads.

For more information on cleaning CORIAN surfaces, go to:

<http://www.dupont.com/products-and-services/construction-materials/surface-design-materials/brands/corian-solid-surfaces/articles/how-to-clean-corian.html>

#### Stainless Steel Sinks

Always apply stainless steel cleaner/polish with a nonabrasive cloth or sponge, working with - not across - the grain.  
Do NOT use ScotchBrite or other abrasive pads.  
Clean with standard house-hold cleaning agents or disinfectant OTHER than chloride products.

#### Chrome Faucets

Do NOT use ScotchBrite or other abrasive pads.  
Clean with standard house-hold cleaning agents or disinfectant OTHER than those containing ammonia, bleach or acid.